

# Technical data sheet



## Product features

### Semi automatic clam grill

<b>Model</b>	<b>SAP Code</b>	00009992
--------------	-----------------	----------



- Top type: Smooth
- Griddle dimensions [mm x mm]: 650 x 480 + 320 x 380 + 320 x 380
- Griddle thickness [mm]: 10.00
- Container for liquid fat: Yes
- Independent heating zones: Separate control for each heating zone on the bottom plate and for the top plates
- Maximum device temperature [°C]: 300
- Surface finish: polished chrome 0.03 mm

<b>SAP Code</b>	00009992	<b>Net Weight [kg]</b>	90.00
<b>Net Width [mm]</b>	658	<b>Power electric [kW]</b>	12.000
<b>Net Depth [mm]</b>	760	<b>Griddle dimensions [mm x mm]</b>	650 x 480 + 320 x 380 + 320 x 380
<b>Net Height [mm]</b>	442	<b>Top type</b>	Smooth

# Technical data sheet



Technical drawing

Semi automatic clam grill

Model

SAP Code

00009992

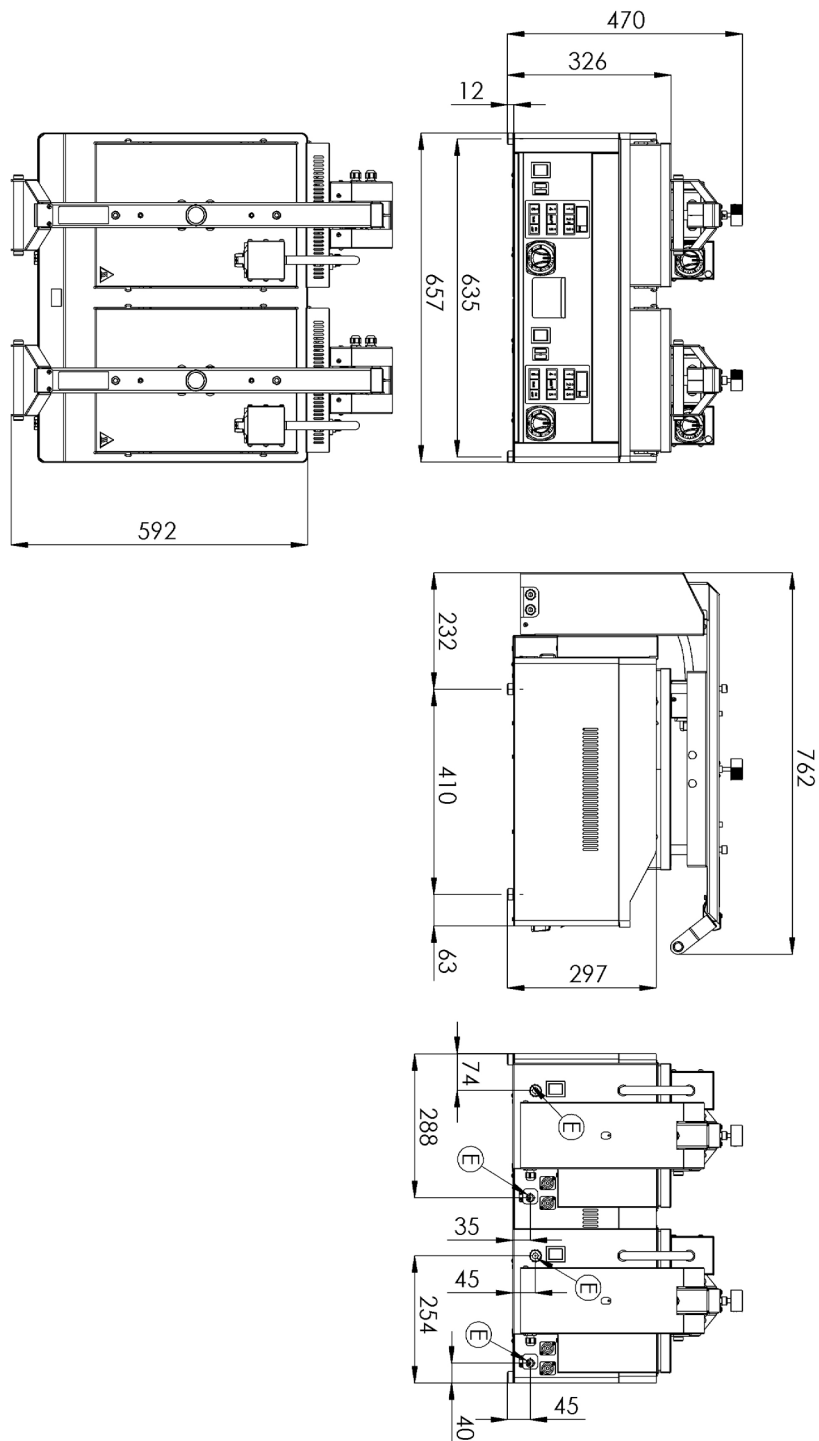

# Technical data sheet



## Technical parameters

### Semi automatic clam grill

Model

SAP Code

00009992

**1. SAP Code:**

00009992

**2. Net Width [mm]:**

658

**3. Net Depth [mm]:**

760

**4. Net Height [mm]:**

442

**5. Net Weight [kg]:**

90.00

**6. Gross Width [mm]:**

725

**7. Gross depth [mm]:**

800

**8. Gross Height [mm]:**

564

**9. Gross Weight [kg]:**

99.00

**10. Construction type of device:**

Table top

**11. Power electric [kW]:**

12.000

**12. Protection of controls:**

IPX4

**13. Material:**

AISI 430

**14. Indicators:**

operation and warm-up

**15. Surface finish:**

polished chrome 0.03 mm

**16. Maximum device temperature [°C]:**

300

**17. Minimum device temperature [°C]:**

50

**18. Griddle dimensions [mm x mm]:**

650 x 480 + 320 x 380 + 320 x 380

**19. Griddle thickness [mm]:**

10.00

**20. Container for liquid fat:**

Yes

**21. Independent heating zones:**

Separate control for each heating zone on the bottom plate and for the top plates

**22. Uniform heating:**

Yes

**23. Top type:**

Smooth